

VERUS ENGINEERING

Front Splitter – Shelby GT350

Install Manual



Author: Tom Lang

Release Date: 2022/24/08

Approvals: E. Hazen

Document Revisions

Rev	Date	Author	Description
01	2022/24/08	T. Lang	Initial release of install manual

Confidential: Property of Verus Engineering. Not for Distribution outside intended recipient list.

CONTENTS

1. Introduction.....	<3>
1.1. Overview.....	<3>
1.2. Difficulty.....	<3>
1.3. Time Required.....	<3>
1.4. Tools Needed	<3>
1.5. Front Splitter Kit Components	<4>
2. Front Splitter Kit Install	<5-24>

Front Splitter, Shelby GT350 – Install Manual

1. Introduction

1.1. Overview: Detailed instructions on installing the Verus Engineering Front Splitter Kit for the Shelby GT350 and Shelby GT350R.

1.2. Difficulty: Moderate

1.3. Time Required: Approximately 2-3 hours

1.4. Tools Needed:

- 1.4.1. Ratchet
- 1.4.2. Extension
- 1.4.3. Cut-off wheel or body saw
- 1.4.4. Tape
- 1.4.5. 5.5mm Socket
- 1.4.6. 7mm Socket
- 1.4.7. 8mm Socket
- 1.4.8. 10mm Socket
- 1.4.9. T30 Torx Socket or Wrench
- 1.4.10. 4mm Allen Socket or Wrench
- 1.4.11. 5mm Allen Socket or Wrench
- 1.4.12. 9/16" Wrench
- 1.4.13. 10mm Wrench
- 1.4.14. Tape Measure
- 1.4.15. Clip Removal Tool, or Flathead Screwdriver



Confidential: Property of Verus Engineering. Not for Distribution outside intended recipient list.

Front Splitter, Shelby GT350 – Install Manual

1.5. Front Splitter Kit Components

- 1.5.1. (1) Splitter Blade
- 1.5.2. (1) Passenger Side Rear Mounting Bracket
- 1.5.3. (1) Passenger Side Middle Mounting Bracket
- 1.5.4. (1) Passenger Side Front Mounting Bracket
- 1.5.5. (1) Driver Side Rear Mounting Bracket
- 1.5.6. (1) Driver Side Middle Mounting Bracket
- 1.5.7. (1) Driver Side Front Mounting Bracket
- 1.5.8. (2) C bracket
- 1.5.9. (1) Passenger Side Air dam
- 1.5.10. (1) Center Air Dam
- 1.5.11. (1) Driver Air Dam
- 1.5.12. (2) 230mm Long Tie Rod
- 1.5.13. (2) 25mm Long Spacer
- 1.5.14. (2) Left Hand Rod End
- 1.5.15. (2) Right Hand Rod End
- 1.5.16. (4) M6x1.0 Clevis
- 1.5.17. **Hardware Bag**
 - 1.5.17.1. (60) M6 x 1.0 25mm Long Button Head Cap Screw, Stainless
 - 1.5.17.2. (48) M6 18mm OD Washer, Stainless
 - 1.5.17.3. (10) 1.50" OD Washer, Stainless
 - 1.5.17.4. (2) M6 x 1.0 25mm Long SHCS
 - 1.5.17.5. (2) M6 x 1.0 16mm Long BHCS
 - 1.5.17.6. (4) 12mm OD Washer, Stainless
 - 1.5.17.7. (2) M6 x 1.0 Fold Nut
 - 1.5.17.8. (34) M6 x 1.0 Serrated Flange Nut
 - 1.5.17.9. (2) M6 x 1.0 100mm Long Socket Head Cap Screw, Stainless
 - 1.5.17.10. (1) 110" Roll of Edge Guard
 - 1.5.17.11. Rivet Nut Installer Tool.



Confidential: Property of Verus Engineering. Not for Distribution outside intended recipient list.

Front Splitter, Shelby GT350 – Install Manual

2. Front Splitter Install

- 2.1. Verus Engineering is not responsible for damage to you or your vehicle by following this manual and/or installing Verus Engineering products.
- 2.2. Jack the vehicle up and support it securely.
- 2.3. Remove the front lip.
 - 2.3.1. First remove the T30 torx, and 7mm hex-head bolts. **NOTE: These instructions will be specifically for the GT350R. Other models are similar but not exactly the same.**

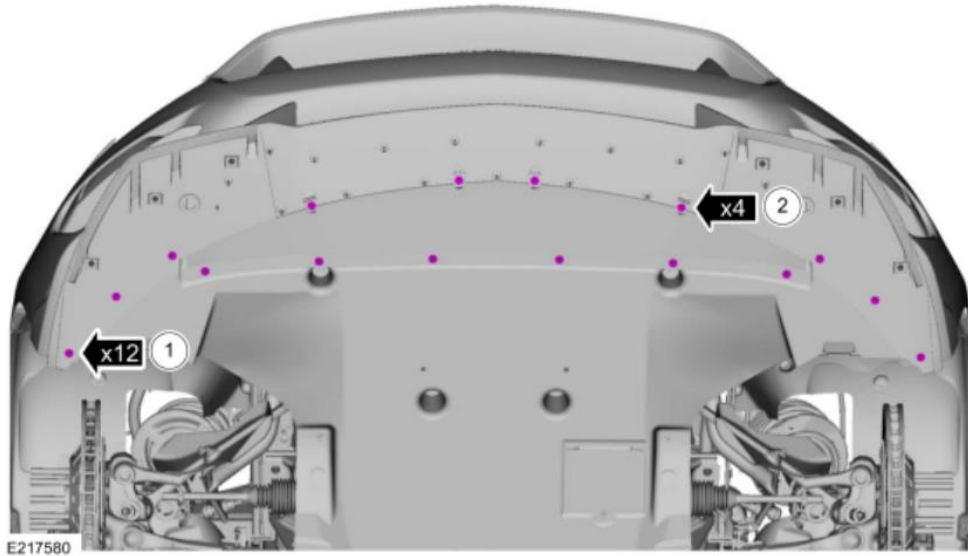

- 2.3.2. Next, remove the bolt covers, and the bolts behind them.



Confidential: Property of Verus Engineering. Not for Distribution outside intended recipient list.

Front Splitter, Shelby GT350 – Install Manual

- 2.3.3.** Finally, remove the fender liner clips (on both sides) to peel back the fender liner enough to remove the retaining clips for the front lip.

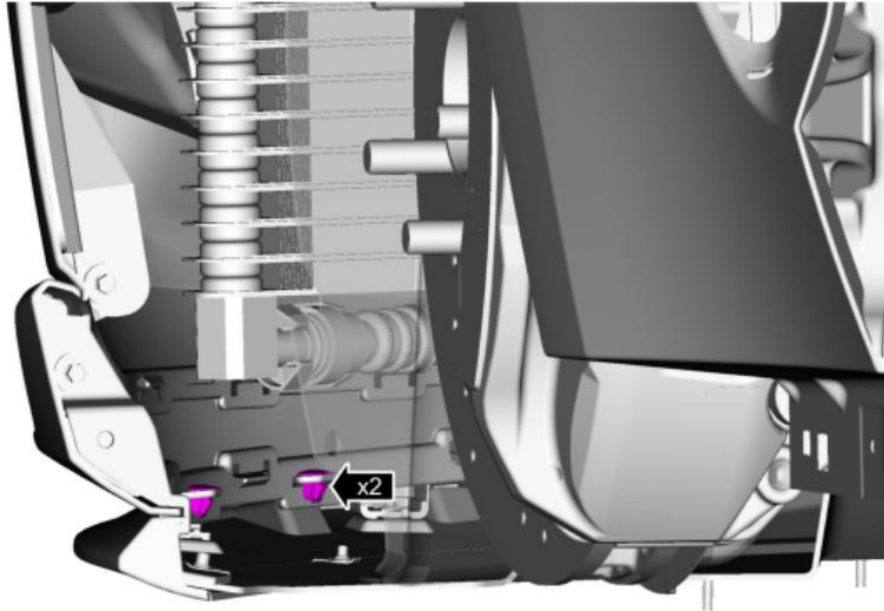

- 2.4.** Next, we will remove the engine under panel, and trim it to fit the splitter mounting brackets.

- 2.4.1.** Remove the bolts with a 7mm socket. Remove the clips in the wheel well (if still present) with a clip removal tool or flat head screw driver. The last clip in the center is a “Christmas tree”- style, simply pulling down on the under panel should release it.

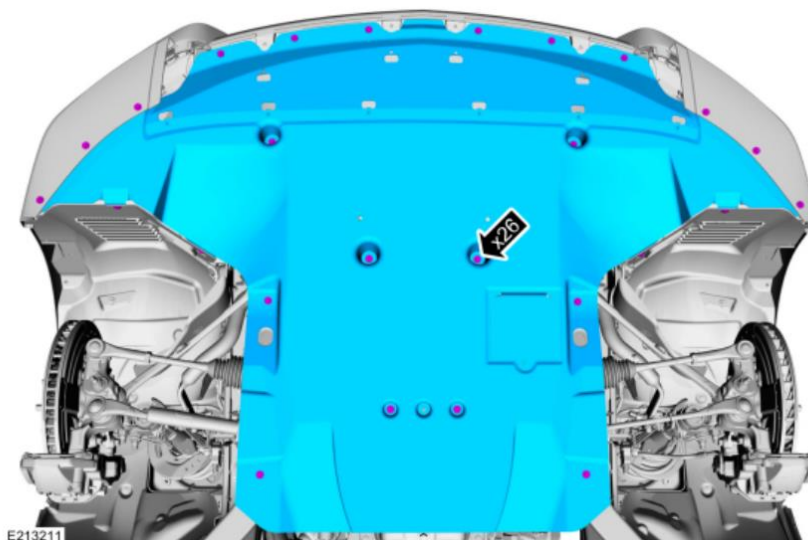

Confidential: Property of Verus Engineering. Not for Distribution outside intended recipient list.

Front Splitter, Shelby GT350 – Install Manual

- 2.4.2. Using the “top side” of the under panel, we will use the strengthening ribs as a guideline for measuring the slot we will be cutting. Follow the guide below as a reference for how to cut out the slot. The passenger side is shown below. Repeat the same process for the driver side but mirrored.

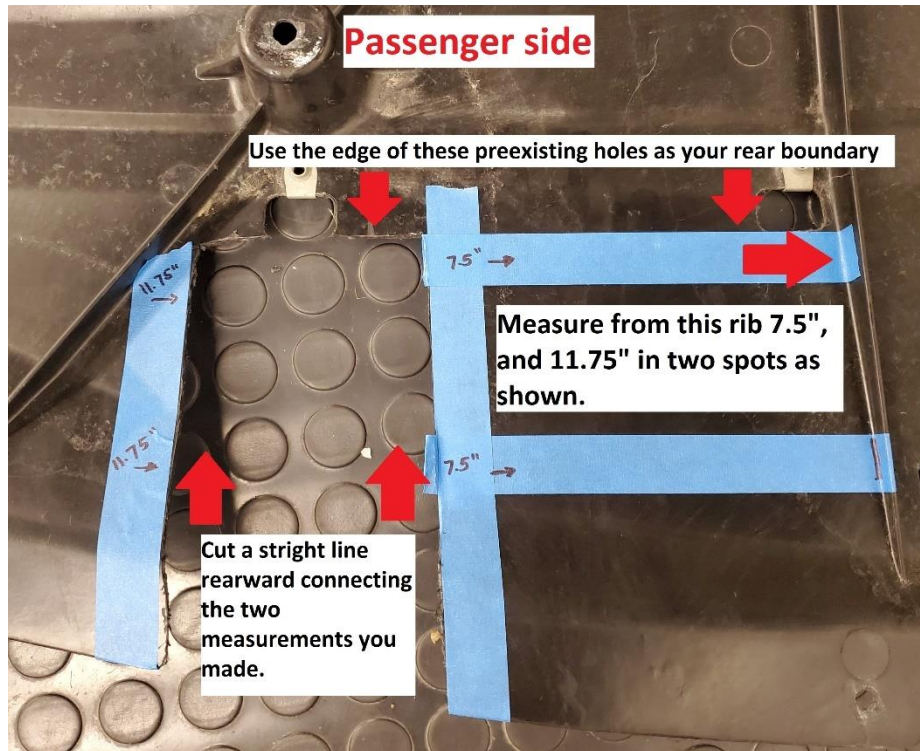

- 2.5. Next, we will remove the front bumper to mount the splitter rods.
- 2.6. Start by removing the top bolts using an 8mm socket and 5.5mm socket. The smaller 5.5mm head bolts will be hiding under the ends of the weather strip.

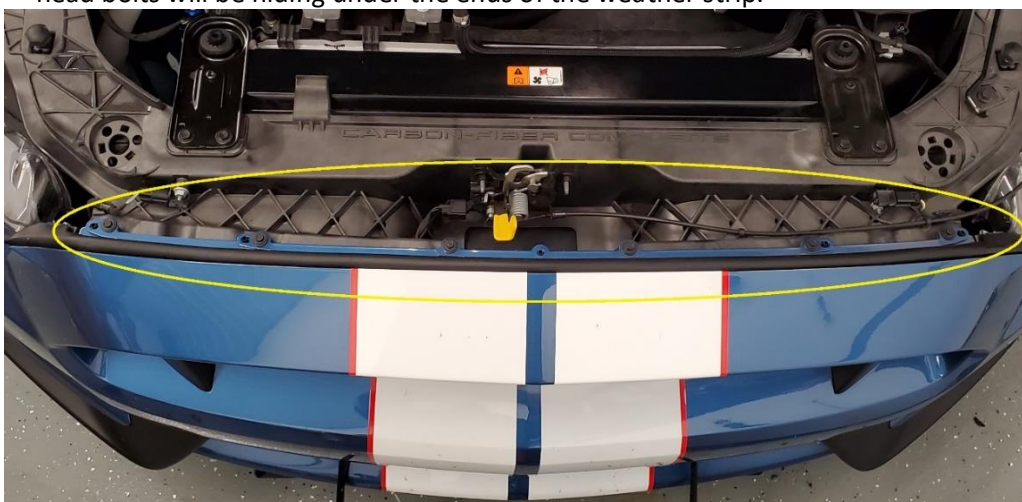

Confidential: Property of Verus Engineering. Not for Distribution outside intended recipient list.

Front Splitter, Shelby GT350 – Install Manual



2.7. Remove the wheel well clips to gain access to the corner bolts. You will only need to remove enough to peel the liner back. You may also completely remove the liner if you like.



Confidential: Property of Verus Engineering. Not for Distribution outside intended recipient list.

Front Splitter, Shelby GT350 – Install Manual

- 2.8. Locate the bumper corner bolts behind the headlights, and use a 7mm socket to remove them.



- 2.9. Disconnect the electrical connectors on both sides.



Confidential: Property of Verus Engineering. Not for Distribution outside intended recipient list.

Front Splitter, Shelby GT350 – Install Manual

- 2.10.** Remove the bumper by pulling slightly up and outward at the corners to release it from the retention brackets first, then completely remove it from the vehicle.
- 2.11.** Measure 10.25 inches from the outside of the crash beam as shown, and make a mark. From there, measure about 5/8" inboard of the crash bar, and make a mark. Make sure the mark is in the center of the bolt hole in the clevis and that the OD is flush with the front of the crash bar.

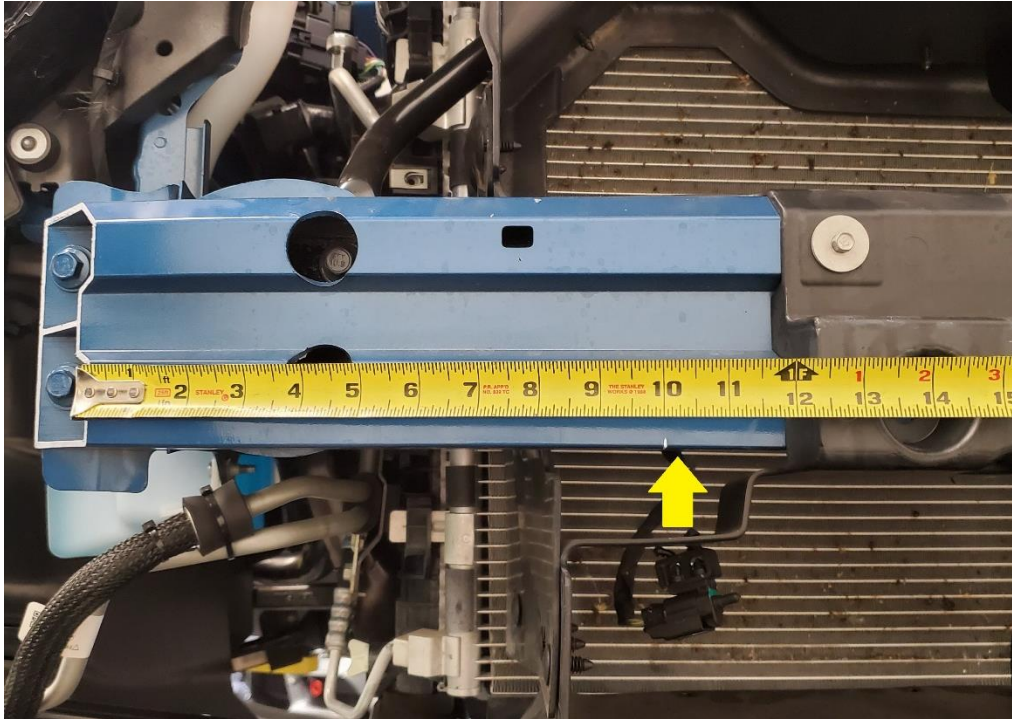

- 2.12.** Repeat for the other side as well.

Confidential: Property of Verus Engineering. Not for Distribution outside intended recipient list.

Front Splitter, Shelby GT350 – Install Manual

- 2.13.** Drill the marked spot on the bottom of the crash beam to 3/8".
- 2.14.** Install the M6 rivet nuts into both holes you just drilled. Follow the instructions below to use the installer tool. Note that the units being installed into the crash beam are not hex, but circular.

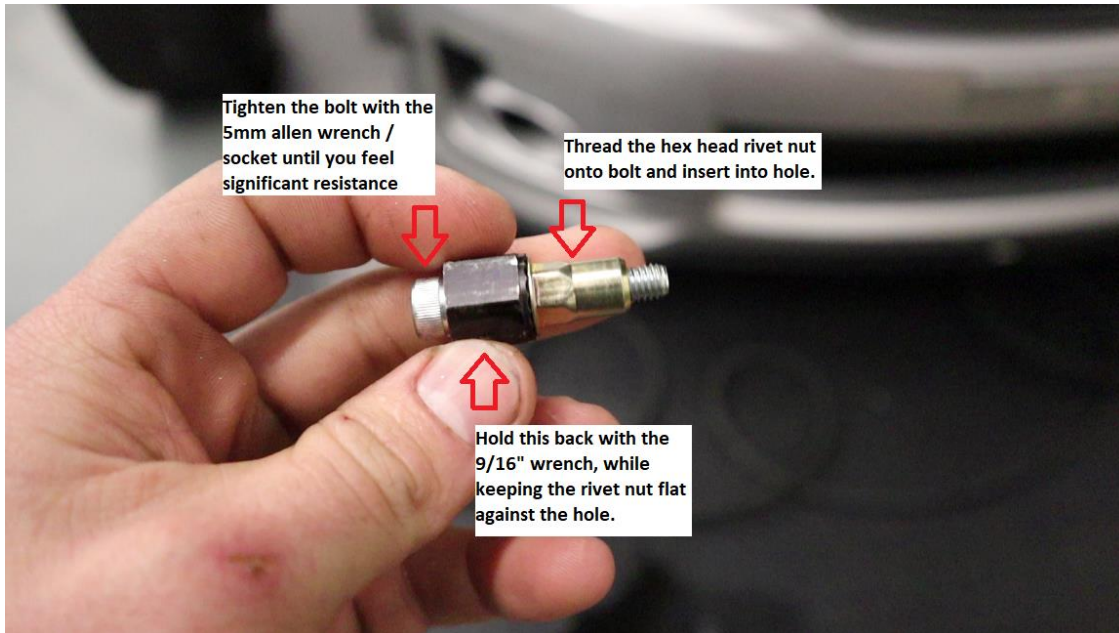

- 2.15.** Locate the two clevises that have the threads drill out, as shown below.



Confidential: Property of Verus Engineering. Not for Distribution outside intended recipient list.

Front Splitter, Shelby GT350 – Install Manual

- 2.16. Use the 25mm Low Profile SHCS to bolt the clevises to the crash bar. Tighten them down to approximately 6 ft-lbs.



- 2.17. Assemble the splitter rods using one 25mm spacer for each rod. **Each splitter rod features LH and RH threads.**



- 2.18. Bolt the splitter rods to the clevises using 25mm BHCS, 12mm washers, and M6 Serrated flange nuts. Tighten to 6 ftlbs. **We recommend installing both splitter rods with the spacer side bolted to the crash bar.**

Front Splitter, Shelby GT350 – Install Manual



- 2.19.** Trim the bumper to clear the splitter rods. Use a pair of cutters and cut the shape shown below.

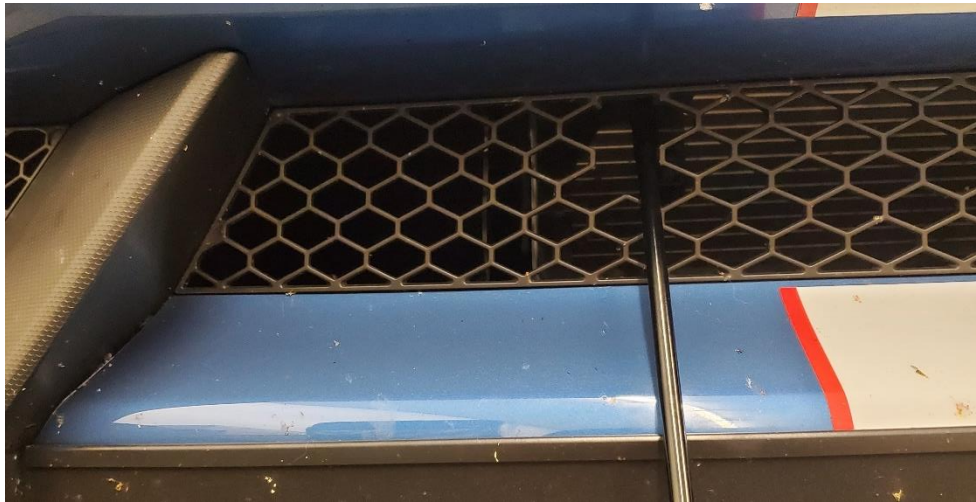

- 2.20.** Re-install the front bumper.
- 2.21.** Assemble the splitter mounting bracket assemblies for both sides.
- 2.21.1.** The splitter mounting bracket assemblies consist of three pieces that will be bolted together prior to being installed on the car.

Front Splitter, Shelby GT350 – Install Manual



2.21.2. Using eight 25mm M6x1.0 BHCS, 18mm washers, and M6 serrated flange nuts, bolt the three pieces together in the orientation shown below. Use the top two holes and the bottom two holes. The center holes are for installing to the car. Driver, and passenger sides will be mirrors of each other. They should also line up with the holes in the splitter.

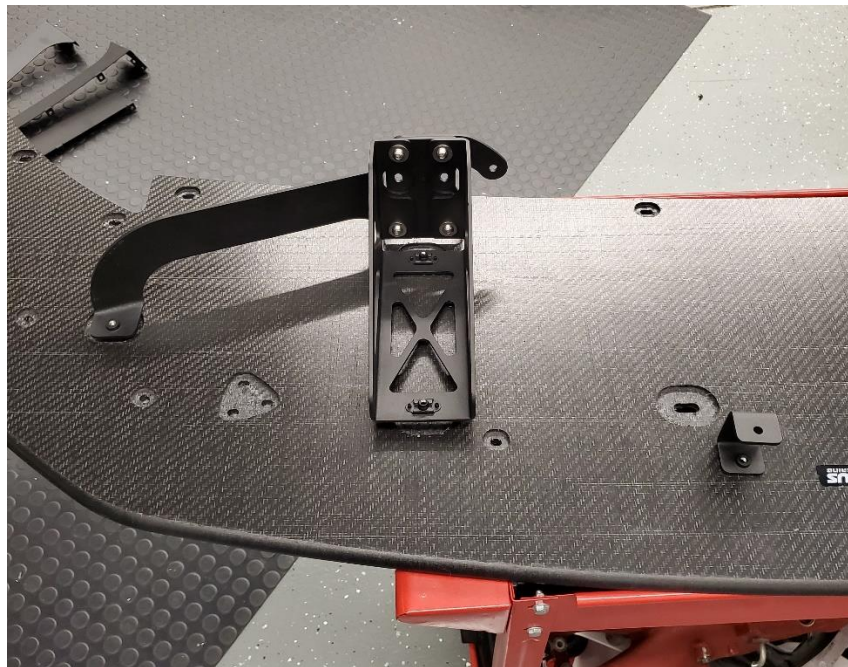

Confidential: Property of Verus Engineering. Not for Distribution outside intended recipient list.

Front Splitter, Shelby GT350 – Install Manual

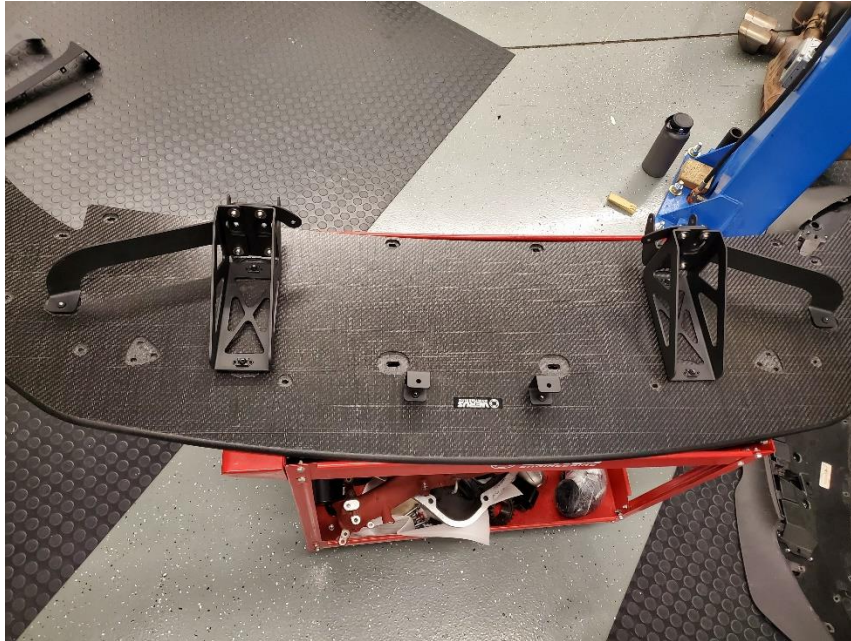

2.21.3. Notice that the rear brackets should have two “ears” pointed towards the rear of the car, and one “ear” pointed towards the center of the car. The middle brackets point outward.

2.22. We will now begin installing the splitter mounting bracket assemblies to the car. Our shop 350R had a bar connecting the two ends of the subframe, and lower radiator ducting. If you have this bar installed, remove it completely it will not be reused.

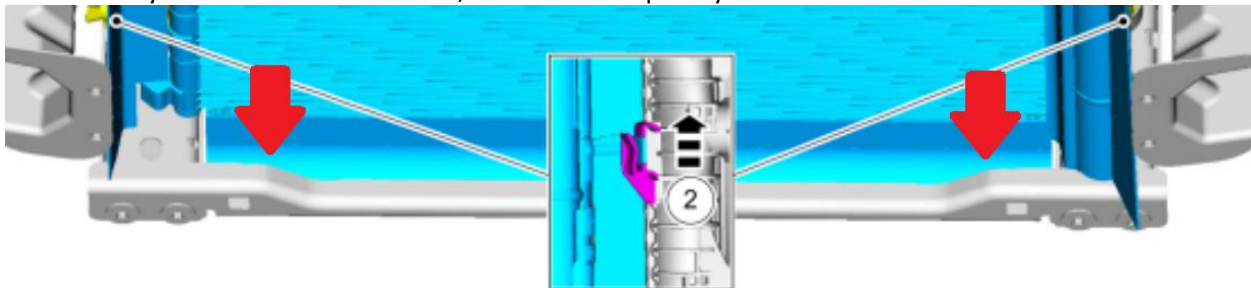

2.22.1. The ends of both subframe rails should have fold nuts currently installed. If not, install the provided M6 fold nuts. **NOTE: We used rivet nuts due to the nature of R&D, and test fits, however the idea here is still the same.**

Front Splitter, Shelby GT350 – Install Manual

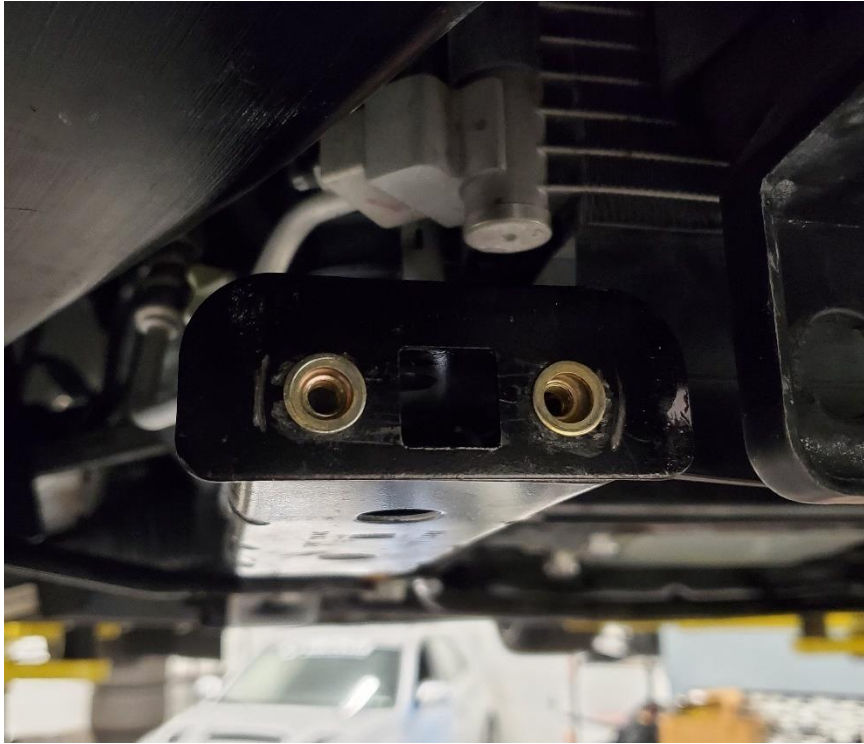

2.22.2. Using four 25mm BHCS, 18mm washers, and the middle set of holes on the bracket assemblies, bolt them to the M6 fold nuts just installed. The two “ears” on the rear bracket pieces should sit on the outside of the frame rails with the third “ear” oriented towards the center of the car lining up the radiator duct hole. If you need a reminder of the bracket orientation refer to the picture in **2.5.2**.

2.22.3. Next, we will use the two 100mm SHCS, 18mm washers, and M6 serrated flange nuts for the rear mounting. Slide the bolt through the bracket “ears” and the frame rail, and install the nut on the other end. Torque to 6t ft-lbs.

2.22.4. Finally, use two 25mm long BHCS, 18mm washers, and M6 serrated flange nuts to bolt the radiator duct to the inner bracket “ears”. Torque to 6 ft-lbs.

2.22.5. When everything is bolted up, it should look like the pictures below.

Front Splitter, Shelby GT350 – Install Manual



Confidential: Property of Verus Engineering. Not for Distribution outside intended recipient list.

Front Splitter, Shelby GT350 – Install Manual

2.23. We are now ready to reinstall the engine under panel. Reinstall the under panel in the reverse of how it was removed. Leave the two front center bolts out. Be sure the under panel clears the mounting brackets sufficiently. If it does not, trim it until it does.

2.23.1. Install the two provided C shaped brackets in the front center under panel holes. Use the factory hardware.

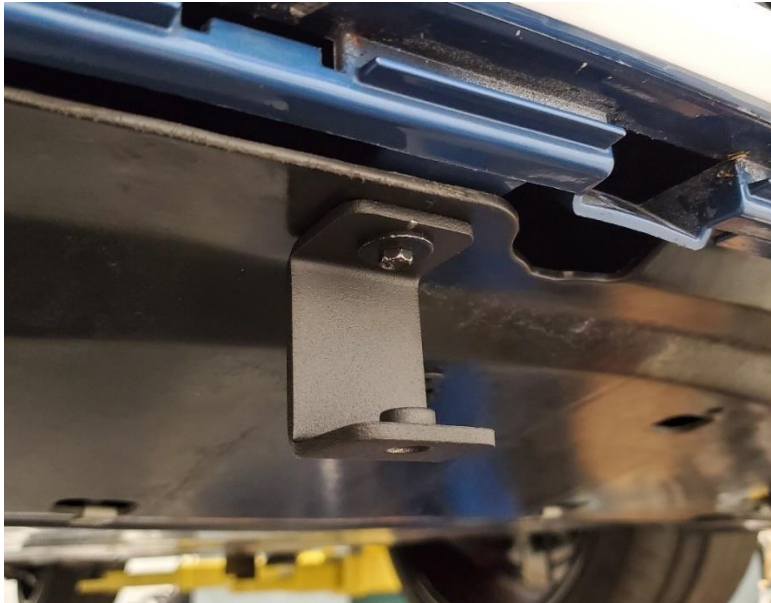

2.24. Now that all the brackets are installed, we will want to level them so that they are the same height. Loosen the four bracket bolts pictured below in order to slide the bracket up or down as needed.



Confidential: Property of Verus Engineering. Not for Distribution outside intended recipient list.

Front Splitter, Shelby GT350 – Install Manual

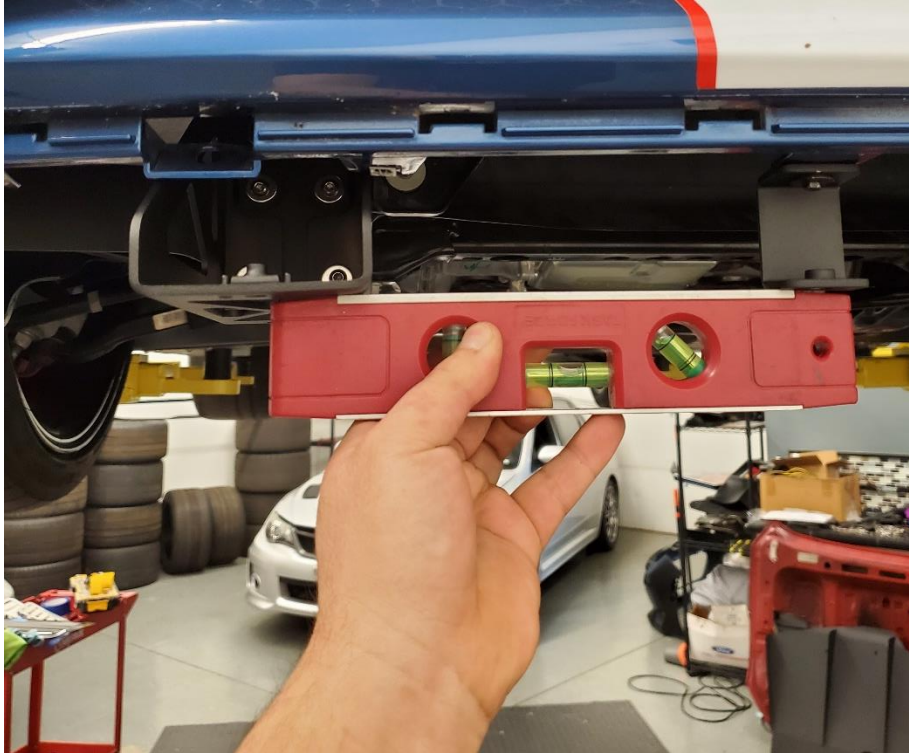

2.24.1. Now the splitter is ready to be installed.

2.24.2. Use eight 25mm long M6 BHCS, and 1.5" OD washers to loosely install the splitter to the mounting bracket assemblies.

2.24.3. Use sixteen more 25mm long M6 BHCS with 18mm washers to loosely install the splitter to the existing holes on the car shown below.

Front Splitter, Shelby GT350 – Install Manual

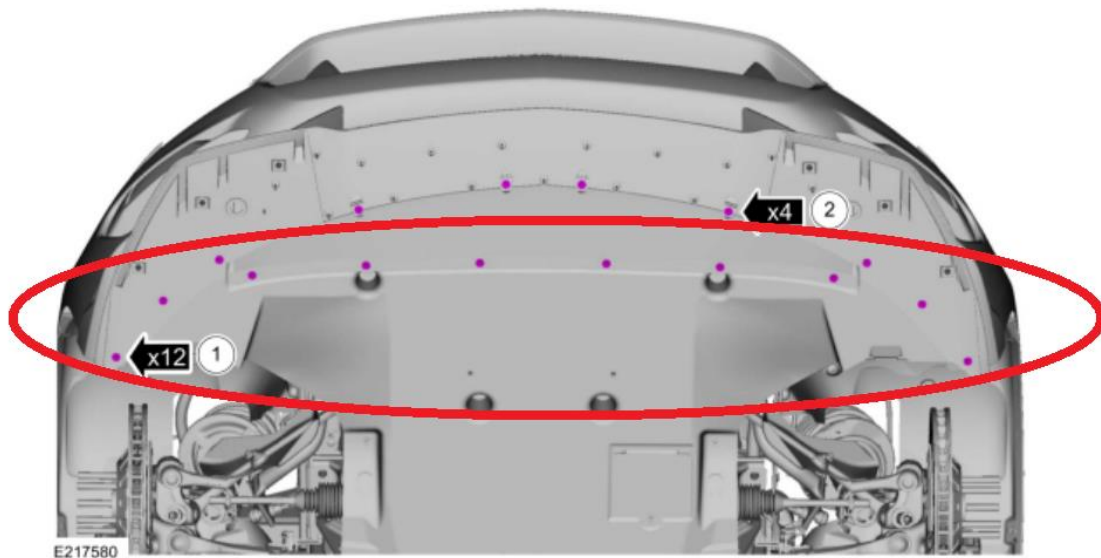

2.24.4. Center the splitter to the car, and torque the bolts to 6 ft-lbs.

2.25. Now that the splitter is mounted to the car, we will start the air dam installation.

2.25.1. The air dam is a three-piece design. The center section does not need to be bent. You should be able to install it as it sits. The side sections however, will need to be bent by hand. Be sure to make small bends/adjustments at a time as the material does not bend back nicely. Take your time, and you will be rewarded with an extremely clean end result.



Confidential: Property of Verus Engineering. Not for Distribution outside intended recipient list.

Front Splitter, Shelby GT350 – Install Manual

- 2.25.2.** With the air dam pieces bent up and fitted correctly, we can start installing it to the splitter.
- 2.25.3.** We will have to remove the splitter to install the air dam pieces.
- 2.25.4.** Notice the center section actually slots into the side pieces.



- 2.25.5.** You will want to start all of the air dam bolts using twenty 25mm long BHCS, 18mm washers, and M6 serrated flange nuts so that the nuts are bottomed against the air dam. This is a crucial step as this will allow for adjustment of the air dam, but also help prevent the nut from spinning during final tightening.
- 2.25.6.** Before torquing the bolts down, cut three sections of the provided edge guard material to the length of each air dam section and install on the top edge. This will help prevent the air dam from scratching the paint. A dab of sealant or silicone helps the edge guard stay on the air dam.

Front Splitter, Shelby GT350 – Install Manual



- 2.26.** Reinstall the splitter onto the car with the 6 chassis locations.
- 2.27.** The air dam is now ready for final tightening. Push the air dam tight against the bumper and tighten the bolts to 6 ft-lbs working outward from the center. Use of a light duty impact helps a lot.
- 2.28.** Install the clevises to the splitter using the large fender washers, and 16mm BHCS. Tighten to 6 ft-lbs.
- 2.29.** Using 20mm BHCS, 12mm washer, and M6 serrated flange nuts install both splitter rods to both clevises.

Front Splitter, Shelby GT350 – Install Manual

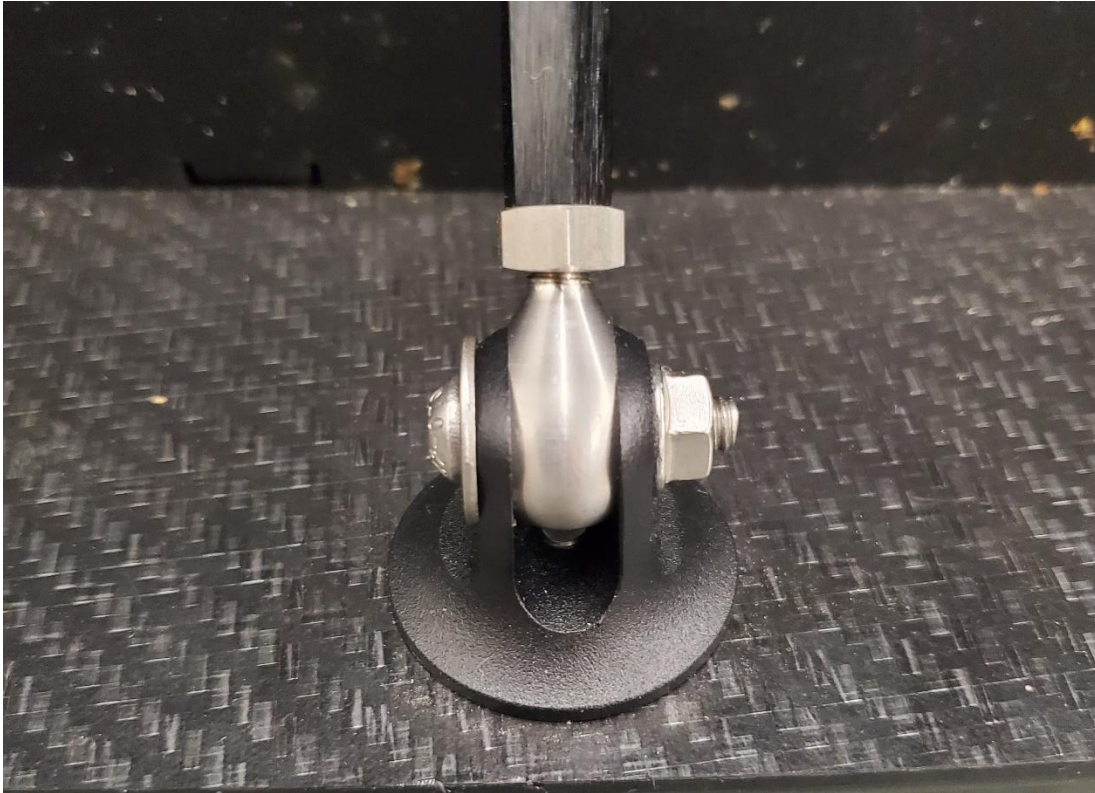

- 2.30.** Congratulations on installing the Front Splitter for the Shelby GT350!
- 2.31.** Please send any questions, comments, concerns, or photos to Verus Engineering via e-mail; sales@verus-engineering.com.

Front Splitter, Shelby GT350 – Install Manual



Confidential: Property of Verus Engineering. Not for Distribution outside intended recipient list.